

ROAD-RATED

ASPHALT MILLING CONVEYOR BELTS

Since 1975, Beltservice Corporation has been manufacturing custom conveyor belting specifically designed to handle the rigors of the asphalt industry. The key to increased life and less downtime is our "Integrally Molded" cleating process. This proven production method features uncured cleats that are molded into our uncured belt. The cleat and belt becomes one homogeneous unit.



- Popular sizes are in stock at several locations for immediate shipment
- Designed to meet or exceed OEM standards
- Versatile profile designs allow for pattern heights from 1/2" to 1-1/4" tall
- Special splicing techniques produce a virtually seamless joint

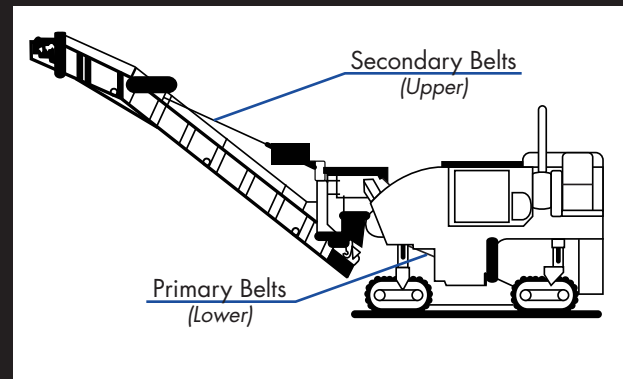

FABFLEX®

A DIVISION OF BELTSERVICE

Beltservice Corporation

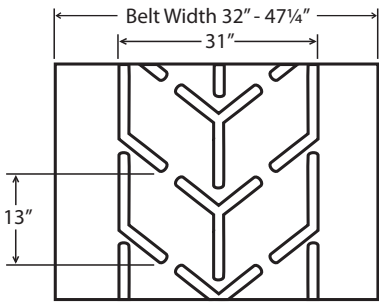

FabClimb 1 1/4" Tall

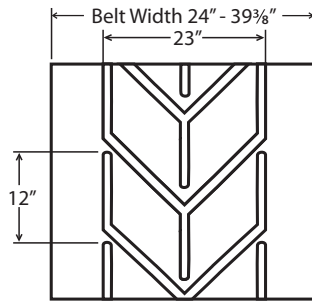

FabClimb 1 1/4" Tall



FabClimb Pattern (Left) vs OEM Pattern

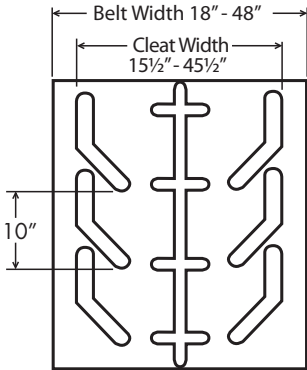

Fablift 1" Tall

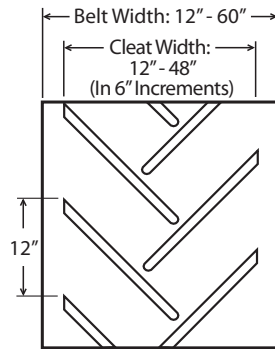

Longhorn 1" Tall

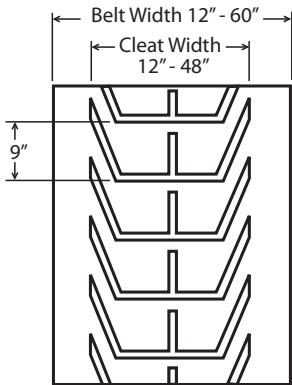

Bighorn 3/4" Tall

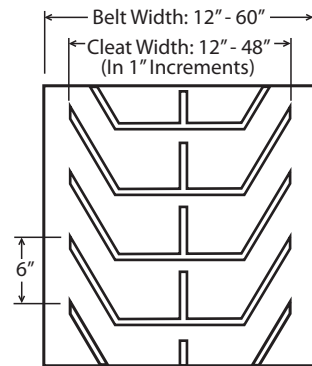

Bullhorn 1/2" Tall

Sizes In Stock To Fit Equipment Manufactured By

- **Roadtec - RX Series**
RX 500, RX 700, RX 900
- **Wirtgen - W Series**
W 1900, W 2000, W 2100, W 2200
- **Caterpillar - PR & PM Series**
PM 200/565
- **CMI - PR Series**
PR 500, PR 600, PR 800, PR 950
- **Bomag - MP Series**
MP 2000
- **Dynapac - PL Series**
PL 2000

Splicing Options

- Super-Screw fasteners
- Vulcanized endless splice
- Flexco Meg Alloy 550
- 8" - 10" minimum pulley diameters
- Tapered cleat ends for smooth transitions
- Available in three belt constructions



Beltservice Corporation

Fabflex Division

696 W. Amity Rd, Boise, ID 83705

PH: 800-423-4469 or Fax: 208-343-8043

sales@beltservice.com, www.beltservice.com

DISTRIBUTED BY:

COLUMBIA RUBBER CORP

800-879-8496